

INSTRUCTIONS - PREDETERMINED INDIVIDUAL TARE WEIGHTS

Establishing Predetermined Individual Tare Weights:

- Deputy weighmaster shall verify the zero-load balance condition of the scale prior to use.
- Determine the weight of the vehicle, container or pallet prior to the time of delivery of a product.
- Deputy weighmaster shall issue a “tare only” certificate for each vehicle, container or pallet for which a predetermined individual tare weight has been established.
- Clearly mark the predetermined tare weight on both sides with the company name or code, and license number. The tare weight shall be identified in numbers and letters not less than three (3) inches (7.62 cm) in height. (See Figures 1, 2, and 3)

Example of a “tare only” certificate issued for an empty truck

| WEIGHMASTER CERTIFICATE 28766 | | | |
|--|---------------|--|-----------|
| THIS IS TO CERTIFY that the following described commodity was weighed, measured, or counted by a weighmaster, whose signature is on this certificate, who is a recognized authority of accuracy, as prescribed by Chapter 7 (commencing with Section 12700) of Division 5 of the California Business and Professions Code, administered by the Division of Measurement Standards of the California Department of Food and Agriculture. | | | |
| Weighed for: ACME FRUIT | | | |
| Delivered to: ACME FRUIT | | | |
| Driver: Art Smith, Smith Trucking | | | |
| WEIGHT IN LB. | | ABC SCALES - Weighmaster | |
| TARE ONLY 8,260 | GROSS TARE | By Susan Morris DEPUTY - DATE 3/1/2015 | |
| NET | | By _____ DEPUTY - DATE _____ | |
| | | Weighed at 1500 Antelope Road Sunnyvale, CA 94086 | |
| | | VEHICLE LIC. # 1A2345 | |
| REMARKS: <i>To establish P.T. weight for a 78 Ford truck.</i> | | UNITS | COMMODITY |
| | | MARKS | |
| | | Empty 78 Ford Flatbed Truck | |

Example of truck with markings for Predetermined Individual Tare

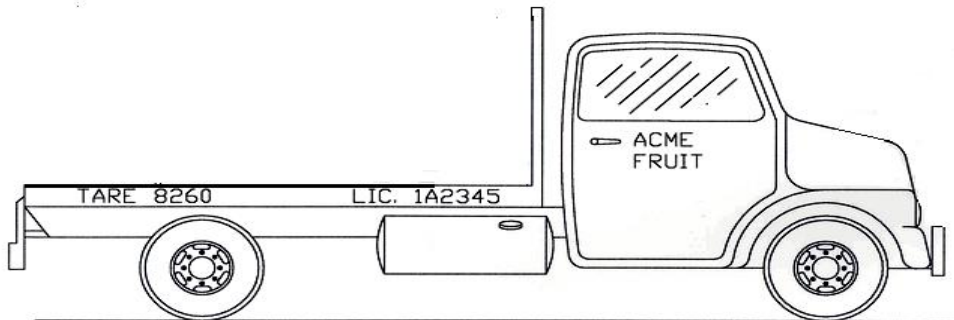

Figure 1.

Example of gondola with markings for Predetermined Individual Tare

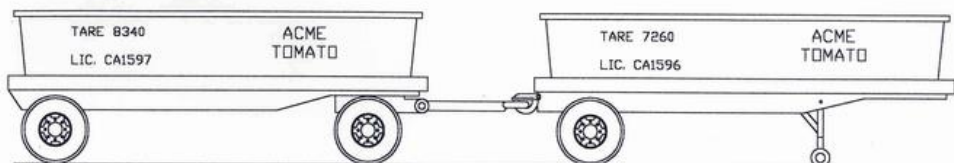

Figure 2.

INSTRUCTIONS - PREDETERMINED INDIVIDUAL TARE WEIGHTS

Example of loaded dual trailers with markings for Predetermined Individual Tare

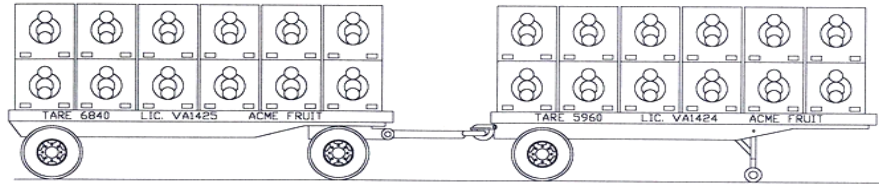

Figure 3.

The following conditions apply to the use of predetermined individual tare weights:

Example of a Predetermined Individual Tare Weight Certificate

| WEIGHMASTER CERTIFICATE | | | | 28766 |
|--|-------|--|-----------------|-------------------------------|
| THIS IS TO CERTIFY that the following described commodity was weighed, measured, or counted by a weighmaster, whose signature is on this certificate, who is a recognized authority of accuracy, as prescribed by Chapter 7 (commencing with Section 12700) of Division 5 of the California Business and Professions Code, administered by the Division of Measurement Standards of the California Department of Food and Agriculture. | | | | |
| Weighed for: ACME FRUIT | | | | |
| Delivered to: ACME FRUIT | | | | |
| Driver: Art Smith, Smith Trucking | | | | |
| WEIGHT IN LB. | | ABC SCALES - Weighmaster | | |
| 79,000 | GROSS | By Susan Morris | | DEPUTY - DATE 6/1/2015 |
| 31,000 | TARE | By Susan Morris | | DEPUTY - DATE 6/1/2015 |
| 48,000 | NET | Weighed at 1500 Antelope Road Sunnyvale, CA 94086 | | VEHICLE LIC. # |
| | | | | TRUCK 1A2345 |
| REMARKS: Cab Card # 4485 - 15400 LB. P.T. 7260 LB. P.T. 8340 LB. Tare Total 31000 LB. | | | | |
| | | UNITS | COMMODITY | MARKS |
| | | | Tomatoes | P.T.7260 WM CERT # 28764 |
| | | | Tomatoes | P.T.8340 WM CERT # 28765 |
| | | | | TRAILER CA1596 |
| | | | | TRAILER CA1597 |

- (a) Predetermined individual tare weights may be used by a weighmaster unless a party having a legal or financial interest in the transaction notifies the weighmaster prior to the issuance of the certificate that a predetermined individual tare weight shall not be used; and
- (b) A weighmaster shall not use a predetermined individual tare weight which is not based on weighmaster records in his/her possession unless furnished with a copy of the "tare only" certificate which established the predetermined individual tare weight; and
- (c) A weighmaster shall not use a predetermined individual tare weight if for any reason it appears that the tare weight may be beyond the tolerance levels prescribed by California Code of Regulations (CCR), Title 4, Division 9, Article 6 Section 4450.

Certificate Requirements:

A predetermined individual vehicle, container or pallet tare weight may be used by a weighmaster to determine the net weight of a commodity, provided the following information appears on the certificate:

- (a) The fact that a predetermined individual tare weight is being used. This may be designated by the letters "P.T."; and
- (b) The predetermined tare weight, company name or code, and license number or serial number of each vehicle, container and/or pallet.

INSTRUCTIONS - PREDETERMINED INDIVIDUAL TARE WEIGHTS

Definition:

A predetermined individual tare weight is the weight of a vehicle, container, or pallet determined by a weighmaster prior to the time of delivery of a product and is established and used in accordance with the regulations authorized by California Business and Professions Code (BPC) sections 12027, 12723, and 12735.

Responsibility:

California BPC section 12722(a) states: In accordance with this chapter and regulations adopted by the secretary, any weighmaster may use a tare weight for a vehicle, container or pallet that has been previously determined by a weighmaster. It is the responsibility of the party for whom the tare weight was established to maintain the tare weight within the variations prescribed by the secretary.

The variations prescribed by the secretary are found in the CCR, Title 4, Division 9, Article 6 Section 4450 and reads in part as follows: "...vehicles and containers for which predetermined individual tare weights...have been established shall be maintained as close as practicable to the established tare weight, but in no event shall such tare weights exceed the tolerance level of two-tenths (0.2) pound or two percent (2%) of the established tare weight, whichever is greater."